



**MICRO BACK  
PRESSURE VALVE**  
**DIRECT ACTING  
STAINLESS STEEL**



**P43**

**DESCRIPTION**

**Mechanical Characteristics:**

Direct Acting Micro Back Pressure Valve. 316 Stainless Steel body, suitable for air, water, and light oil. Large lower diaphragm is more sensitive to low pressures. Adjustment is via stem (12) which alters the gate, effecting the outlet pressure. The pressure gauge accurately indicates the outlet pressure. Available with BSP or NPT ports, or PN16 Flanges.



Pressure Adjusting Range:  
• 0.02 - 0.2 Bar

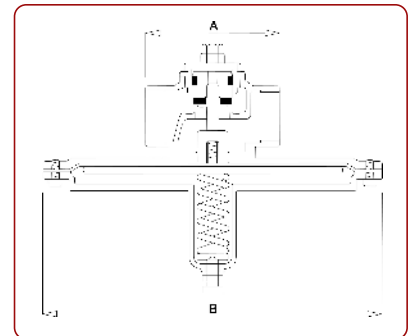
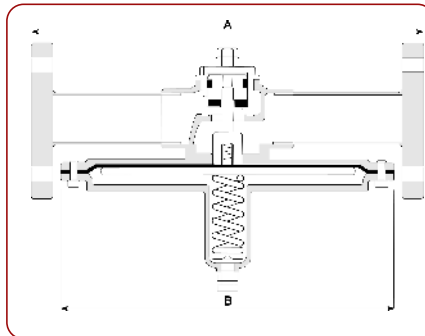

**SPECIFICATIONS & DIMENSIONS**

Model: Screwed Port				Orifice mm	Nominal Pressure	Pressure in Bar		KV Flow Factor L/Min.	Weight Kg	Dimensions mm	
A	B	C	test pressure			A	B				
P43	I	15	F/G	1/2"	15	10	16	35	*	70	*
P43	I	20	H/I	3/4"	20	10	16	129	*	85	*
P43	I	25	L/M	1"	25	10	16	157	*	90	*
P43	I	40	O/V	1 1/2"	40	10	16	300	*	115	*
P43	I	50	P/W	2"	50	10	16	357	*	120	*

\* Depends on sustaining set pressure

Flow Chart for Air at 50°C

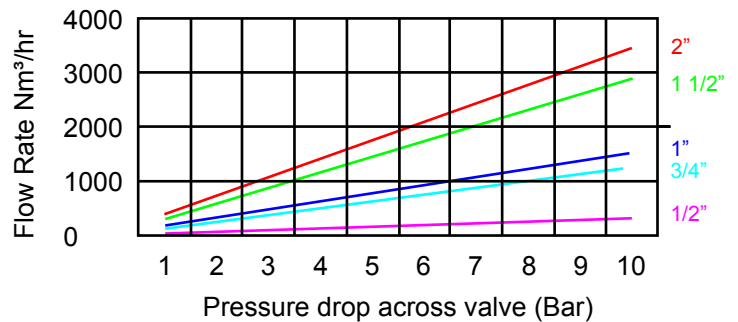

**ORDER CODES**

A	Body	B	Ported Body	C	Seals (fluid temp. min / max)	
I	316 Stainless Steel	F	1/2" BSP	G	1/2" NPT	1 VITON (-10°C to + 90°C)
		H	3/4" BSP	I	3/4" NPT	
		L	1" BSP	M	1" NPT	
		O	1 1/2" BSP	V	1 1/2" NPT	
		P	2" BSP	W	2" NPT	

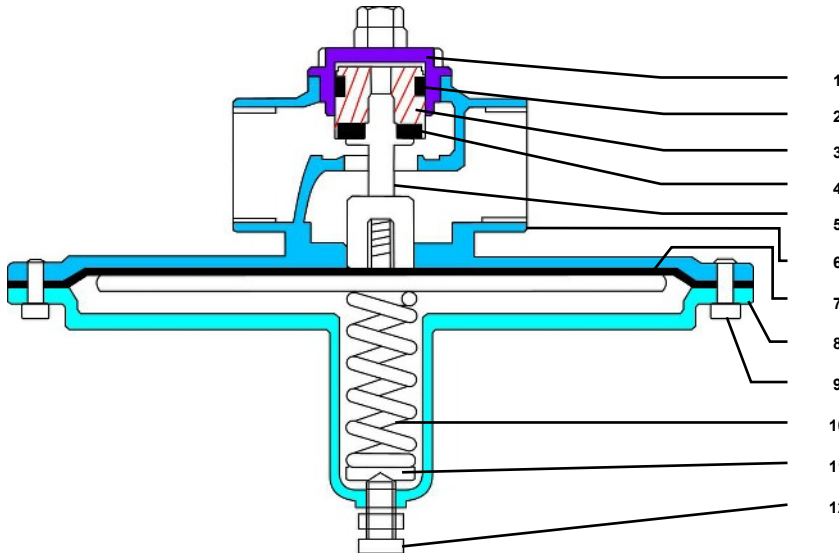
**THE INSTALLATION OF MICRO BACK PRESSURE VALVE**

Part	Part Name	Material
1	Cover	316 Stainless Steel
2	UH-Ring	Depends on the media
3	Piston	316 Stainless steel
4	Sealing	Depends on the media
5	Shaft	316 Stainless Steel
6	Main Body	316 Stainless Steel
7	Diaphragm	Depends on the media
8	Spring Cover	316 Stainless Steel
9	Stem	304 Stainless Steel
10	Spring	Spring Steel
11	Washer	Brass
12	Stem	304 Stainless Steel

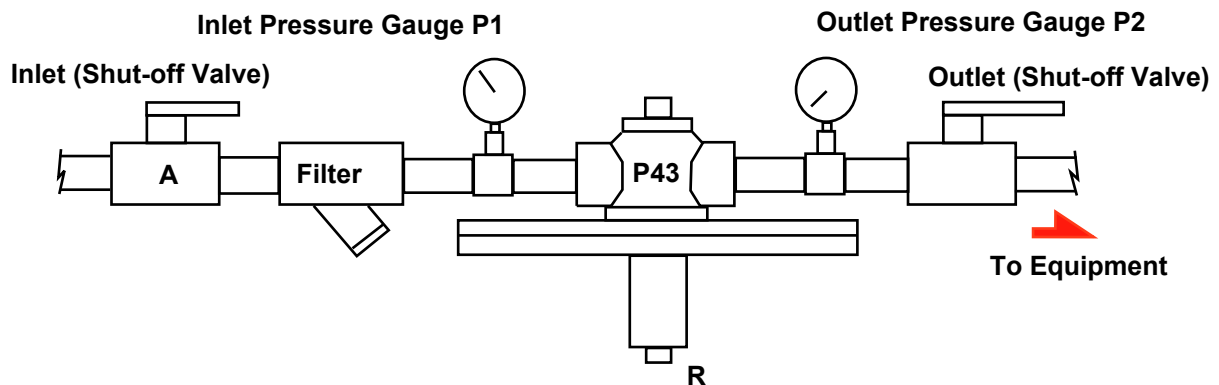
**THE INSTALLATION PROCEDURE**
**Before Installation:**

1. Clean & remove all impurities inside the pipe. A filter is recommended upon installation.
2. Make sure the direction of the valve is observed with respect to the media flow.
3. The set pressure increases by turning the adjusting stem R (12) clockwise.
4. The Pressure Gauge indicates the Outlet Pressure.
5. The P43 must be installed in the horizontal plain, with the adjusting stem R down.

**Adjusting The Set Pressure:**

1. Make sure shut off valves A and B are closed.
2. Turn the adjusting stem R anti-clockwise to completely reduce any pressure.
3. Fully open Valve B and then open valve A to a third of fully open.
4. Close valve B slowly and make sure the pressure gauge P2 is in the normal range.
5. If correct, slowly turn valve B fully closed.
6. Turn adjusting stem R clockwise (in) to the desired set pressure.
7. Slowly turn valve A from 1/3 open to fully open.
8. Shut off valve B slowly to check the reducing valve can function.
9. Open and close valve B several times slowly, in order to check whether the pressure remains at the desired set point.
10. Open valve B, and fix the adjusting stem to the correct set pressure.